



DANISH
—Sohail—

Make The Wardrobe Space Simpler And More Organized

www.danishsohailgroup.com



DANISH
—Sohail—

danishsohailgroup.com

Wardrobe Storage Products



Location



Whatsapp

Email: dshardware.official@gmail.com

Telephone Number: +92 316 410 7770

Facebook: [dshardware](#)

Instagram: [dshardware](#)

Youtube: [@danishsohailgroup](#)



In order to provide
a comfortable living environment for every family



HISTORY

1975

Year Established

Wholesale Clients

Wholesale Clients Nationwide

Retail

Elite Buyers

Company Profile

Founded by visionary entrepreneur **Muhammad Danish Ibn Sohail**, **DS Group** is a leading provider of innovative solutions in the fields of **hardware, kitchen, wardrobe, media wall, and construction of house's**. Rooted in a legacy dating back to 1975, our company is built on the core values of excellence, creativity, and customer satisfaction.

With a strong presence in the hardware industry for decades, we've grown into a diversified brand that brings quality and innovation together. Our extensive network includes **nationwide customers**, a testament to our reputation and commitment to excellence.

Our Departments:

DS Hardware

Focused on delivering premium hardware solutions, this department caters to industries such as construction, furniture, and manufacturing. We offer a curated range of products including handles, knobs, hooks, and other essential accessories.

DS Ambience

This department specializes in creating immersive living and working environments. From **hinges** to **kitchen and wardrobe accessories**, we transform everyday spaces into personalized lifestyle statements.

DS Render

Combining technology with design, our rendering division provides high-quality **3D visualizations** and **architectural renders**, empowering professionals to showcase their concepts with precision and realism.



CONTENTS



LEATHER JEWELRY BOX	01-06
STRETCH BOX	07-10
TROUSER PANT RACK	11-16
LEATHER STORAGE BASKET	17-22
SHOE RACK	23-28
HIDDEN CODE DRAWER	29-32
ROTATING SHOE RACK	33-38
SINGLE PULL DOWN HANGER	39-42
CLOTH CORNER SAVER	43-46
MOUNTED DOUBLE-ROW PANT RACK	47-50
TOP-LOADING SINGLE-ROW TROUSERS RACK	51-54
AUTOMATIC WATCH WINDER	55-58



DANISH
—Sohail—

LEATHER JEWELRY BOX



Leather Jewelry Box





WARDROBE STORAGE

Series

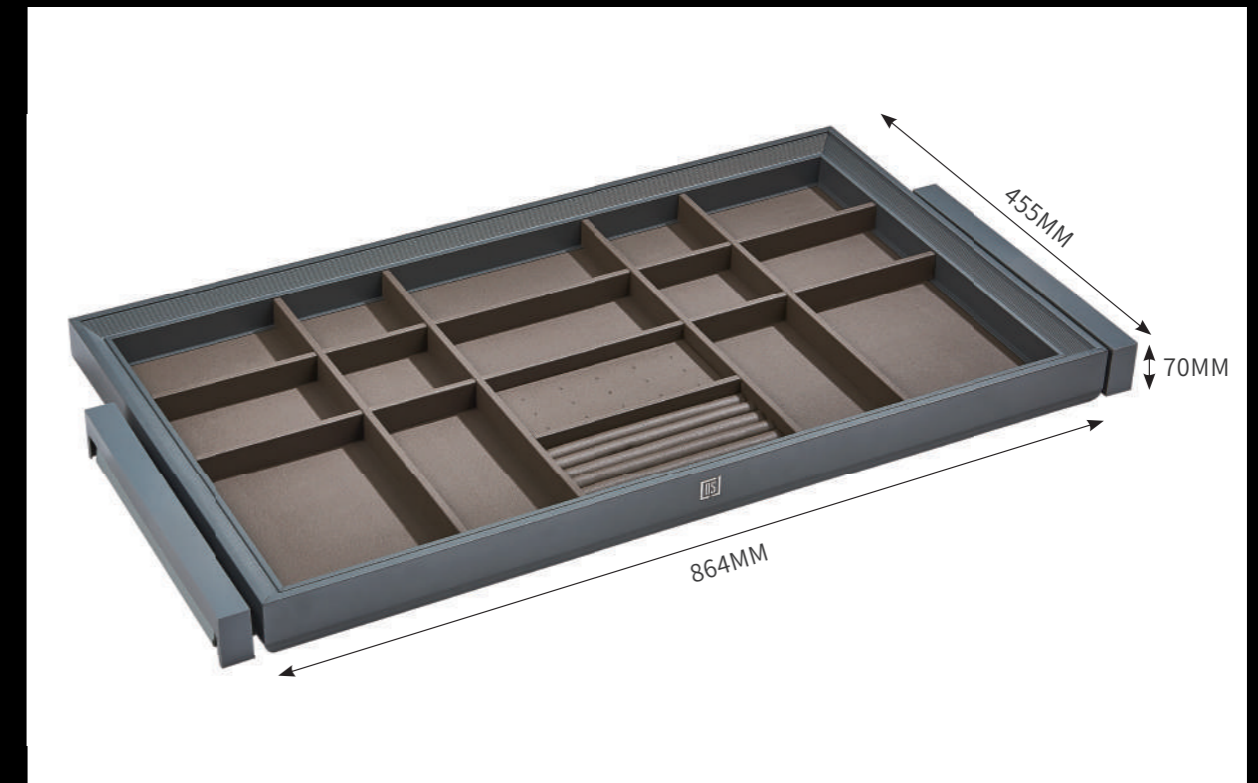

LEATHER JEWELRY BOX

Item	COLOR	SURFACE TREATMENT	Description	SIZE (LxWxH)
1201	Grey+Brown	Fluorocarb spraying	The main frame is made of space aluminium alloy, with brown leather in lychee pattern.	564x455x70mm
				864x455x70mm

STRETCH BOX





WARDROBE STORAGE

Series



STRETCH BOX

Item	COLOR	SURFACE TREATMENT	Description	SIZE (LxWxH)
A05	Brown	Fluorocarb spraying	The main frame is made of space aluminium alloy, with brown leather in lychee pattern.	500-800x410x60mm



TROUSER PANT RACK



Trouser Pant Rack

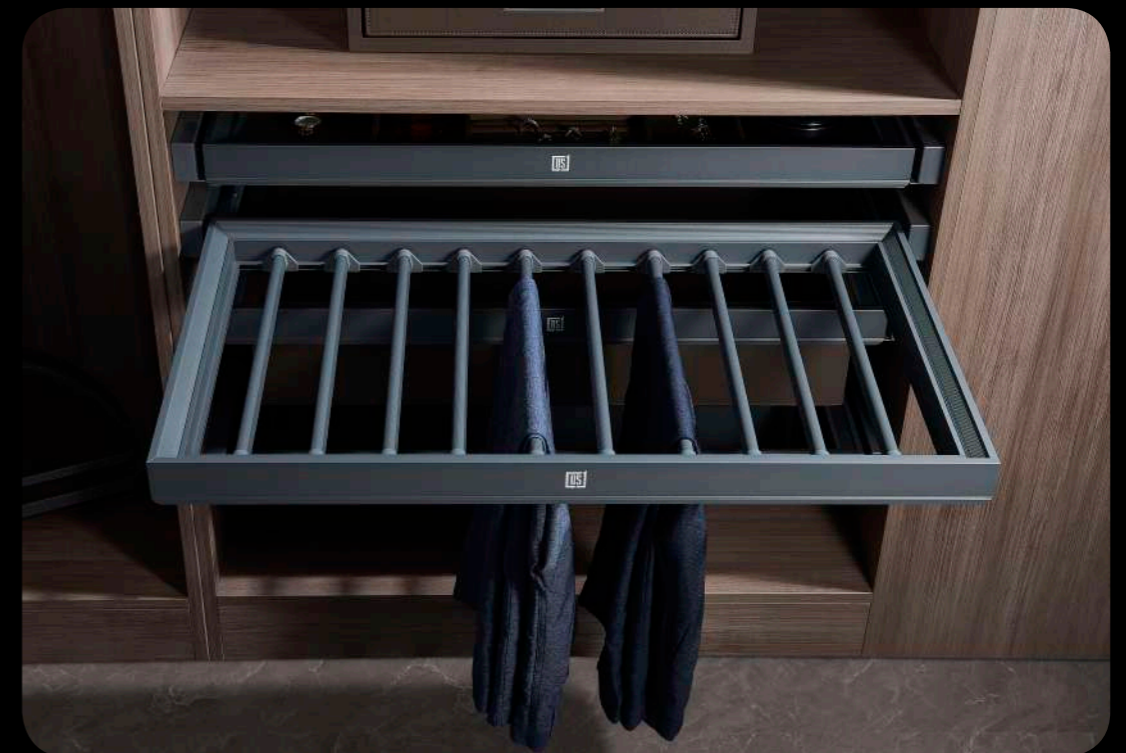



WARDROBE STORAGE

Series

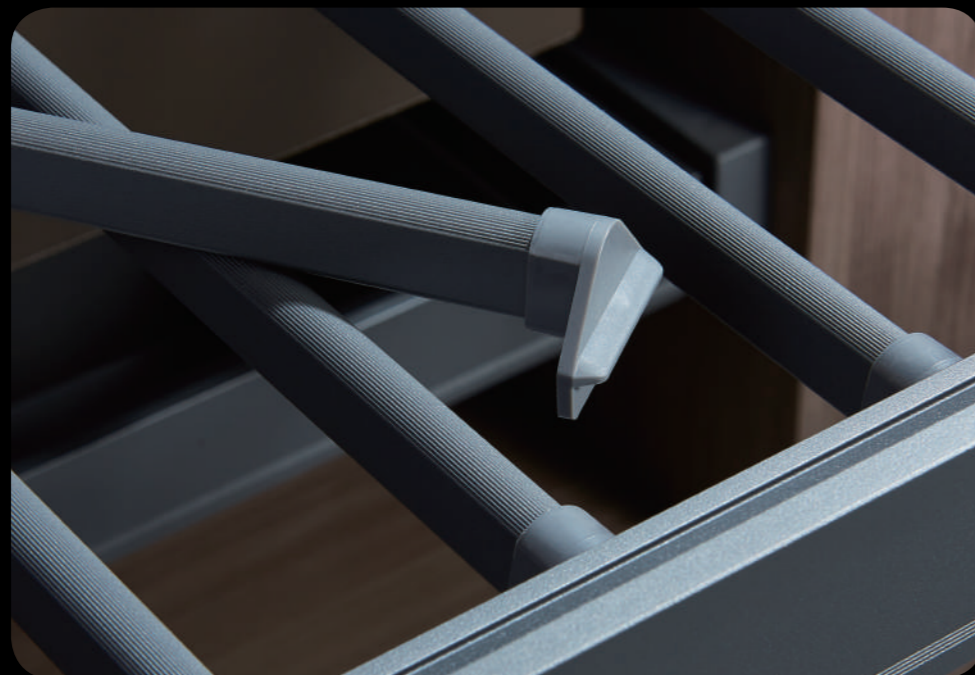

Building home order through storage, optimizing and creating a clean and organized home space

TROUSER PANT RACK

Item	COLOR	SURFACE TREATMENT	Description	SIZE (LxWxH)
1203	Grey	Fluorocarb spraying	The main frame is made of space aluminium alloy, with brown leather in lychee pattern.	564x455x70mm
				864x455x70mm

LEATHER STORAGE BASKET





Leather Storage Basket



WARDROBE STORAGE

Series

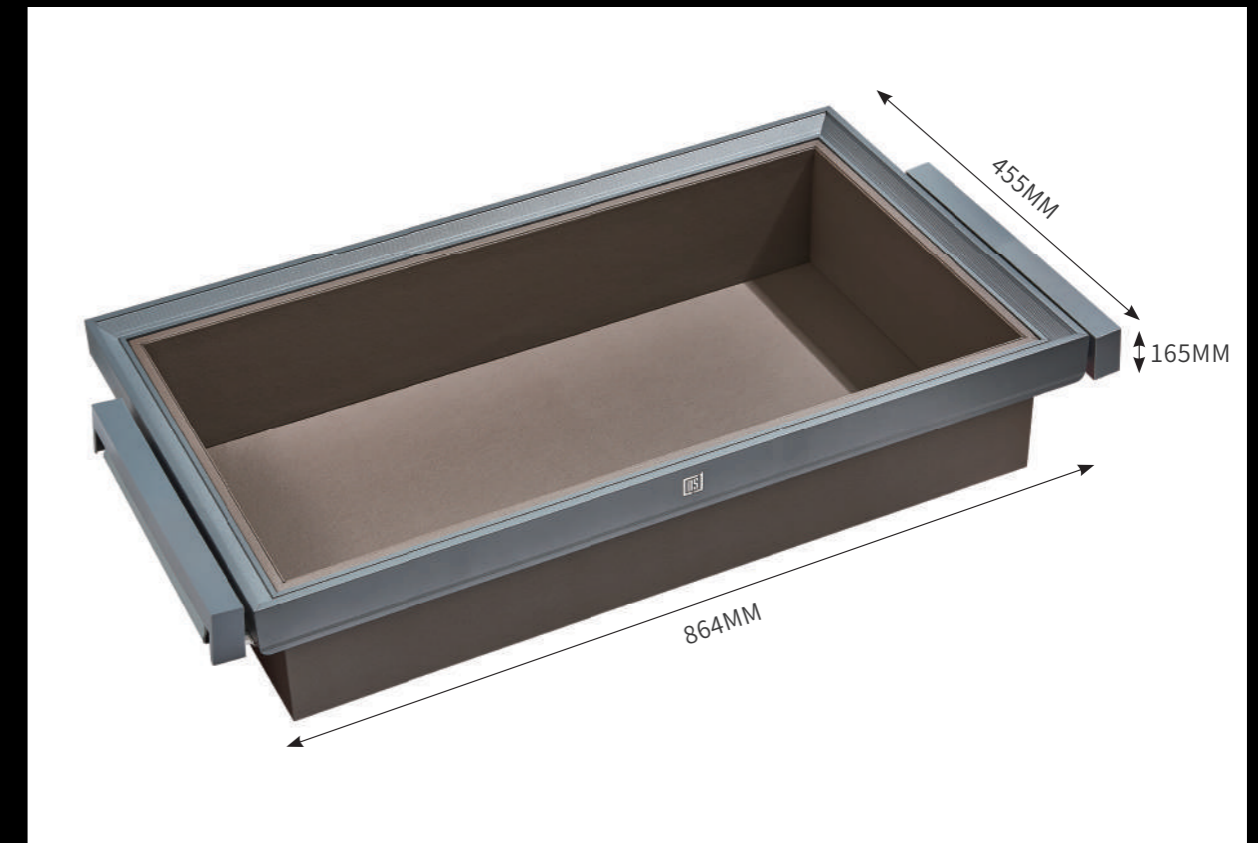

LEATHER STORAGE BASKET

Item	COLOR	SURFACE TREATMENT	Description	SIZE (LxWxH)
1206	Grey+Brown	Fluorocarb spraying	The main frame is made of space aluminium alloy, with brown leather in lychee pattern.	564x455x165mm
				864x455x165mm



SHOE RACK



Shoe Rack



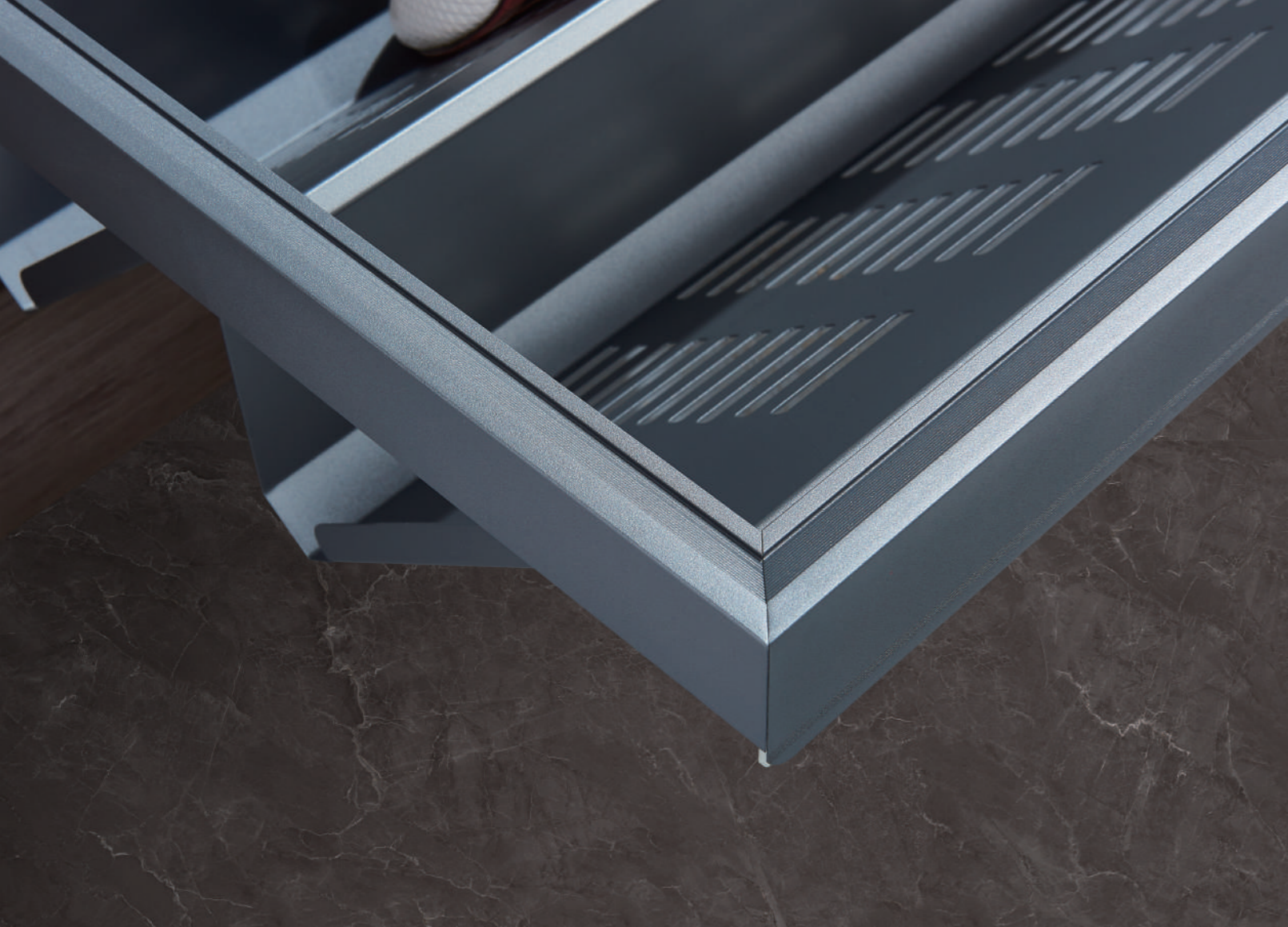

WARDROBE STORAGE

Series



Without too many intricate decorations, the collision of noble leather patterns and metal can better highlight the nobility of personal items

SHOE RACK

Item	COLOR	SURFACE TREATMENT	Description	SIZE (LxWxH)
1204	Grey	Fluorocarb spraying	The main frame is made of space aluminium alloy, with brown leather in lychee pattern.	864x455x165mm



HIDDEN CODE DRAWER





WARDROBE STORAGE

Series



HIDDEN CODE DRAWER

Item	COLOR	SURFACE TREATMENT	Description	SIZE (LxWxH)
B06	Brown	Fluorocarb spraying	The main frame is made of space aluminium alloy, with brown leather in lychee pattern.	464x402x152mm

ROTATING SHOE RACK



DANISH
—Sohail—



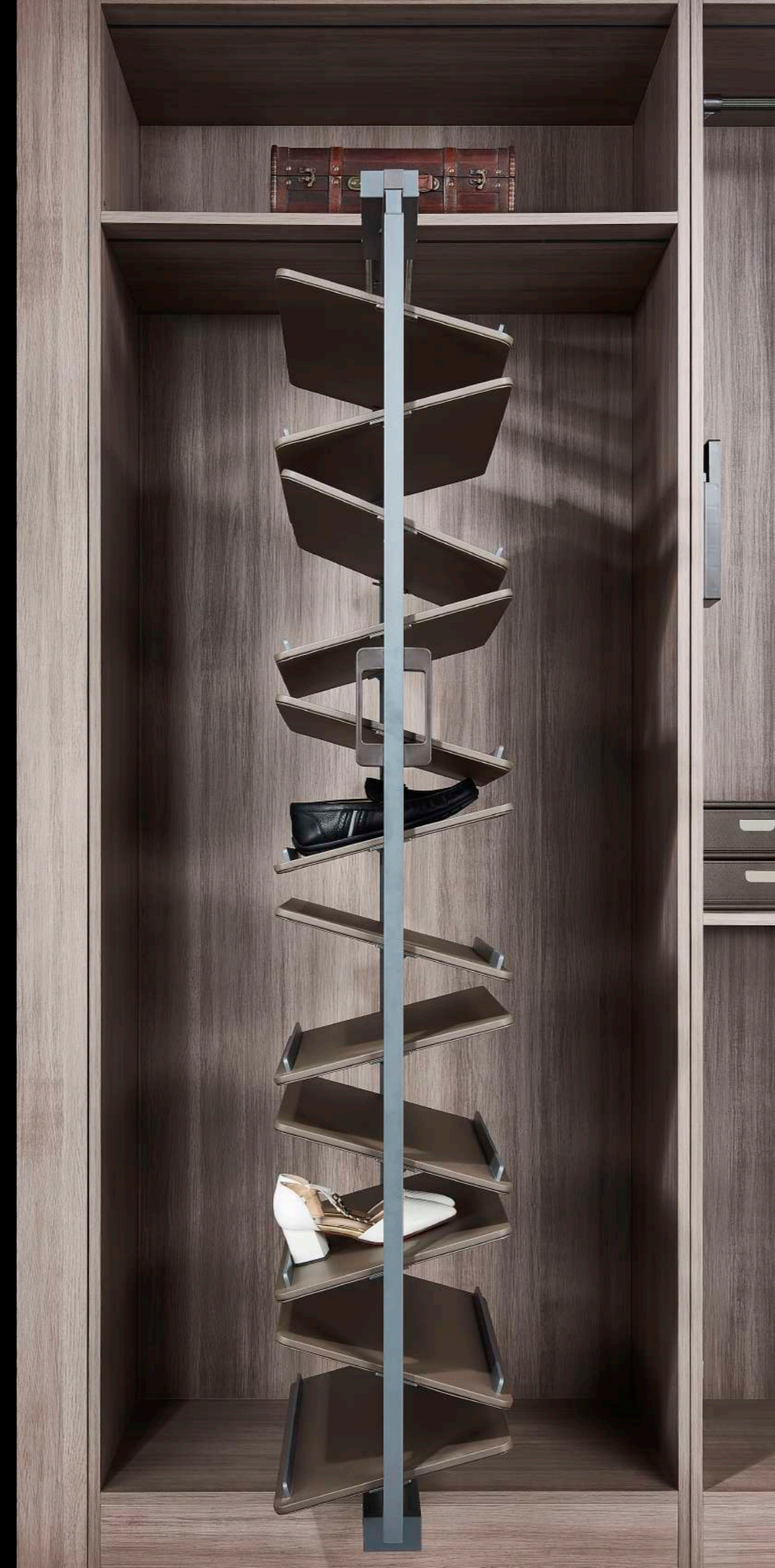



Simple Orderly Quality Of Life



WARDROBE STORAGE

Series

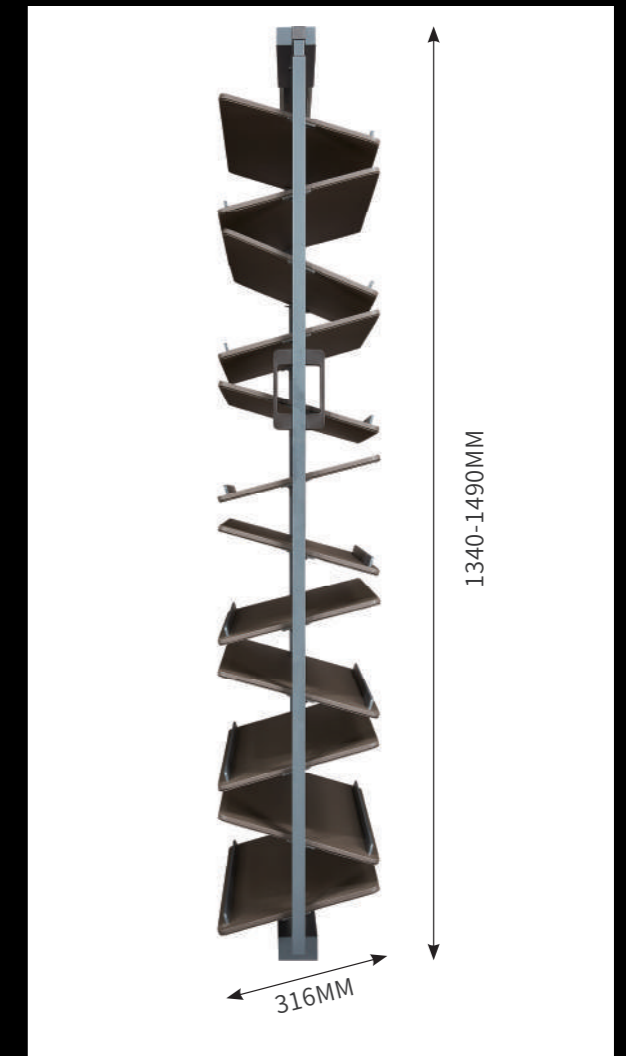
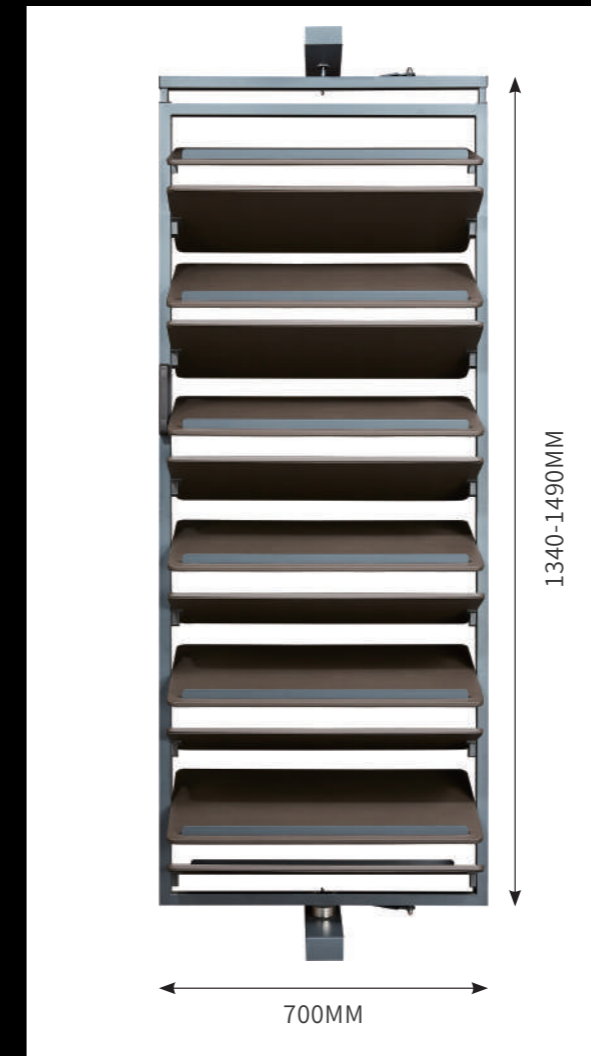

ROTATING SHOE RACK

Item	COLOR	SURFACE TREATMENT	Description	SIZE (LxWxH)
1301	Grey+Brown	Fluorocarb spraying	The main frame is made of space aluminium alloy, with brown leather in lychee pattern.	700x(1340-1490)x316mm
				700x(1900-2050)x316mm

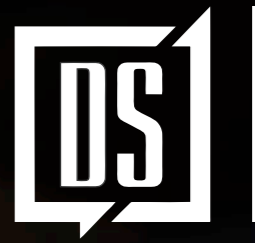

DANISH
—Sohail—

SINGLE PULL DOWN HANGER



WARDROBE STORAGE

Series



SINGLE PULL DOWN HANGER

Item	COLOR	SURFACE TREATMENT	Description	SIZE (LxWxH)
B01	Brown	Fluorocarb spraying	The main frame uses space aluminium	930-1250mm

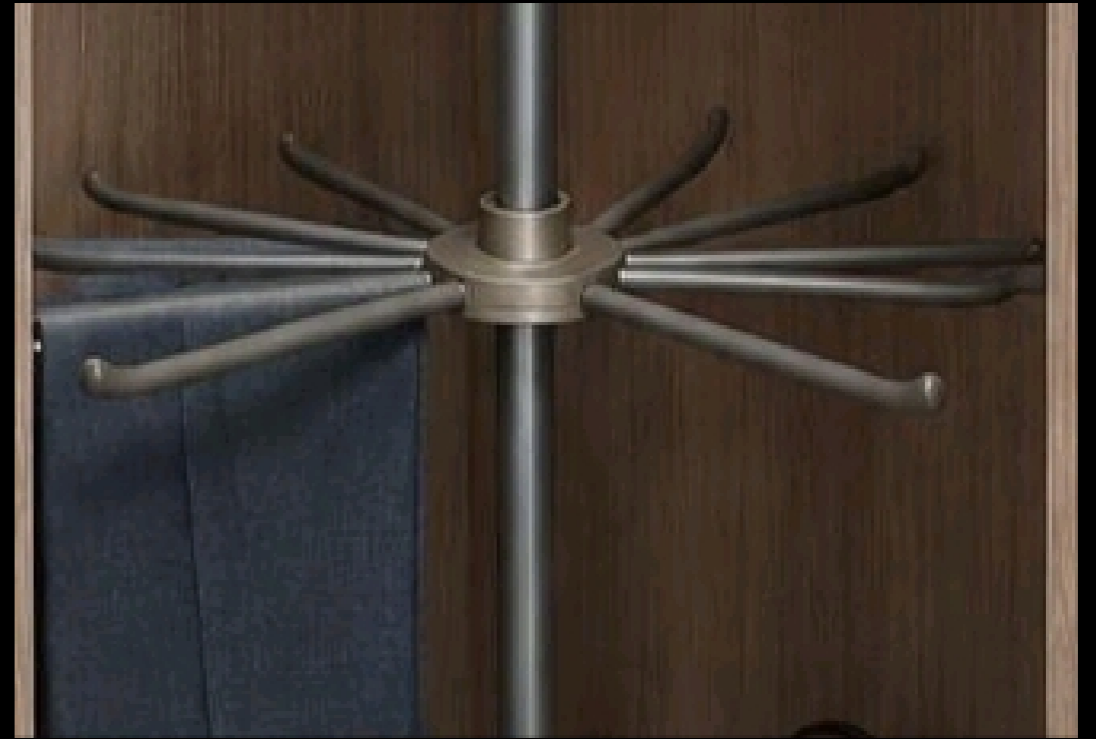

Cloth-Corner Saver





WARDROBE STORAGE

Series

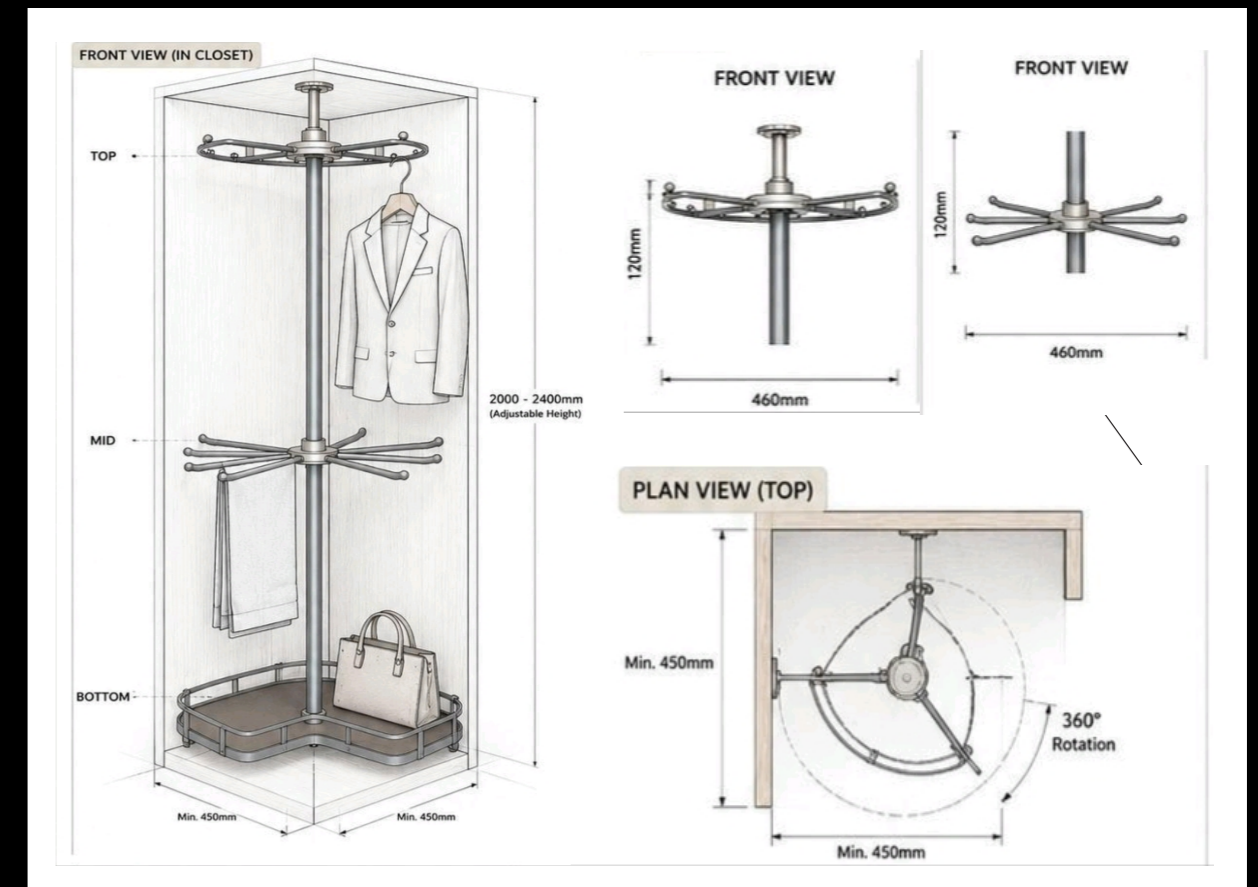

CLOTH CORNER SAVER

Item	COLOR	SURFACE TREATMENT	Description	SIZE (LxWxH)
1208	Grey+Brown	Fluorocarb spraying	The main frame uses iron fittings and cotton tubes.	100mm Standard Cabinet size



Mounted Double-Row Pant Rack





WARDROBE STORAGE

Series

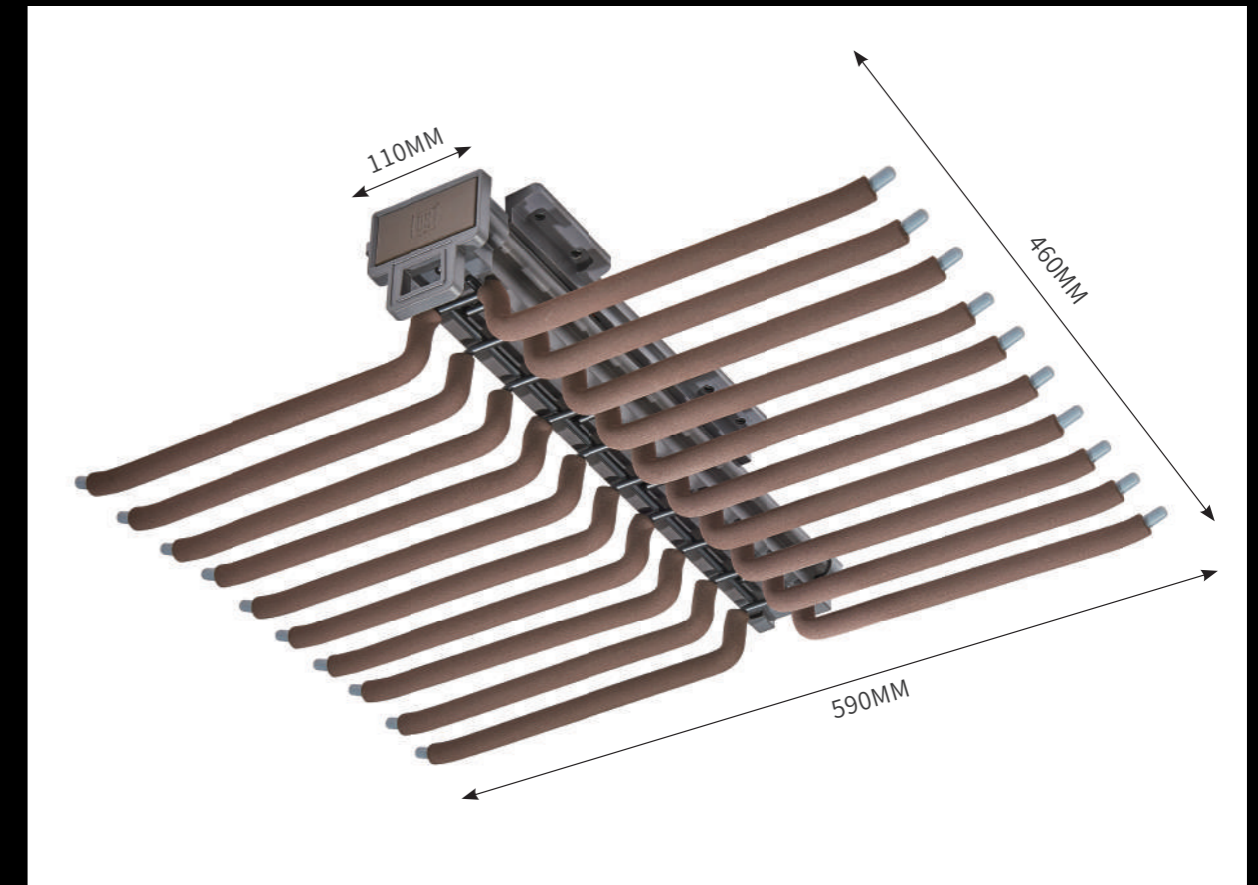

MOUNTED DOUBLE-ROW PANT RACK

Item	COLOR	SURFACE TREATMENT	Description	SIZE (LxWxH)
B03	Grey+Brown	Fluorocarb spraying	The main frame uses iron fittings and cotton tubes.	460x590x110mm



Top-Loading Single-Row Trousers Rack / Tie Rack

WARDROBE STORAGE

Series

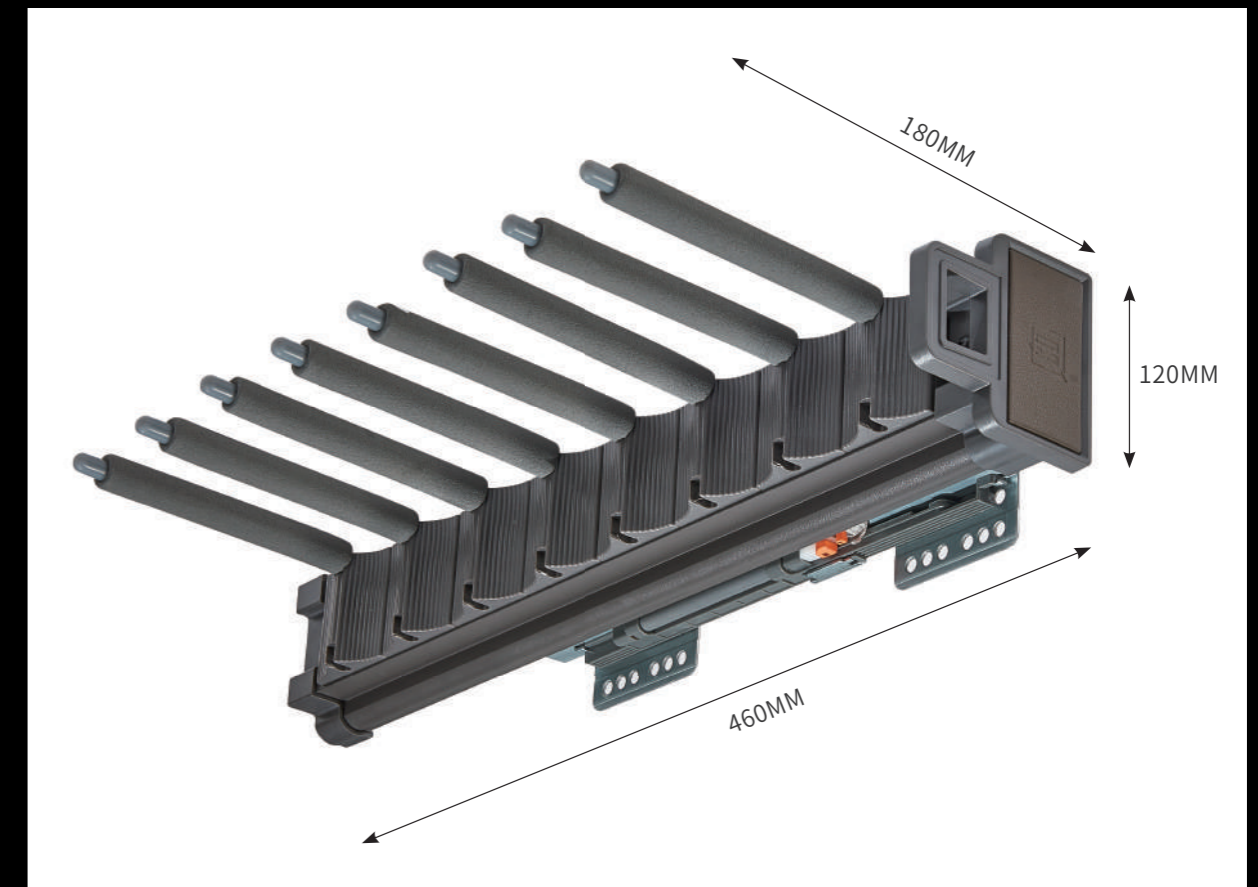

TOP-LOADING SINGLE-ROW TROUSERS RACK / Tie Rack

Item	COLOR	SURFACE TREATMENT	Description	SIZE (LxWxH)
B07	Grey+Brown	Fluorocarb spraying	The main frame uses iron fittings and cotton tubes.	460x180x120mm



AUTOMATIC WATCH WINDER



WARDROBE STORAGE

Series



AUTOMATIC WATCH WINDER

Item	COLOR	SURFACE TREATMENT	Description	SIZE (LxWxH)
1209	Grey+Brown	Fluorocarb spraying	The main frame uses iron fittings and cotton tubes.	220x856x270mm